

FL Series

SURFACE DISINFECTION UVC FIXTURES

Fixed surface disinfection UV fixtures are engineered for high-level disinfection of contaminated surfaces that can spread infection. These units are permanent UV fixtures for use in daily disinfection. Disinfection procedures and cleaning protocols focus heavily on high-touch surfaces, but there are other surfaces we are constantly in contact with, such as floors, that benefit from disinfection. The FL series is designed for continuous floor disinfection to ensure that pathogens are not transferred as easily via contact. Benefits include:

- Designed specifically for continuous floor disinfection
- Constructed of stainless steel and aluminum
- All units feature specular reflectors for increased UVC efficiency
- 120 through 277 V AC 50/60 Hz operation
- Philips Germicidal Sterilamp® tubes for reliable lamp availability and cost efficient replacement; PL-L 18W TUV have no more than 4.5 mg mercury content and produce no ozone
- Solid state electronic ballast for low energy use, reliability, and operational safety

Ideal for food manufacturing and healthcare applications.



9000 hour lamp life.



Wall-mounted 18" from the floor in occupied areas.



PL-L 18W TUV have no more than 4.5 mg mercury content and produce no ozone.

Models

There are two available models using 18W output to meet various disinfection requirements.

FL Series

SURFACE DISINFECTION UVC FIXTURES

FL Product Specifications

Standard Specifications

Lamp Specs	PL-L 18W TUV (non proprietary)
Wavelength	254 Nanometers*
Expected Lamp/Bulb Rated Life ¹	18 months
Lamp Socket	Single Ended, 4 Pin, 2G11
Input Voltage	Self Regulated Electronic UV Ballast 120V
Electrical Requirement	1.3A @ 120V to 0.56A @ 240V, 50-60Hz
Housing Finish	Stainless Steel & Aluminum
Weight	FL-118 - 16 lbs., FL-218 - 18 lbs.

Certifications:



ASHRAE	meets ASHRAE TC 2.09
EPA ²	EST. NO. 91347-TN-001
ETL	CDR100230620ATL-001A

¹With 80% utilization
²The manufacturer is registered with the US EPA. Clinical lab testing has been performed in independent labs.

Warranty Lamps/2 years; Parts/5 years

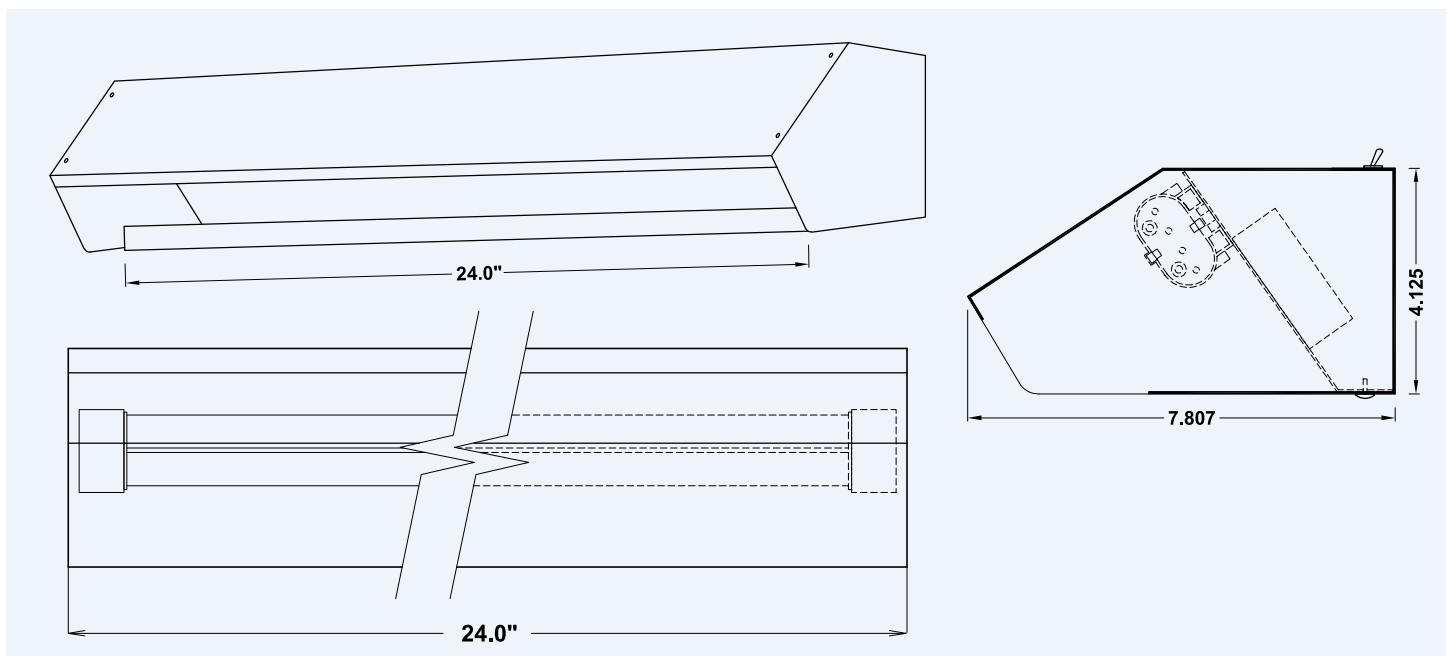

Due to continuing research, Lumalier reserves the right to change specifications without notice.

Ordering Guide

Model#	Description
FL-118	Facing down @ floor; one 18 W, horizontal 9" lamp; open housing, 120°
FL-218	Facing down @ floor, two 18 W, horizontal 9" lamps; open housing, 120°