



UVS Series

SURFACE DISINFECTION UVC FIXTURES

Fixed surface disinfection UV fixtures are engineered for high-level disinfection of contaminated surfaces that can spread infection. These units are permanent UV fixtures for use in daily disinfection. The UVS series units are designed for personal workspace and station UVC disinfection. When small work areas or stations require constant and consistent cleaning procedures, the UVS can expedite these cleansing protocols with ready and quick UVC disinfection. Benefits include:

- Designed for use in personal workspaces
- Constructed of stainless steel and aluminum
- All units feature specular reflectors for increased UVC efficiency
- 36 to 72 UV watts output and designs to meet various disinfection requirements
- Philips Germicidal Sterilamp® tubes for reliable lamp availability and cost efficient replacement, PL-L 36W TUV, have no more than 4.5 mg mercury content and produce no ozone
- 120 through 277 V AC 50/60 Hz operation.
- Solid state electronic ballast for low energy use, reliability, and operational safety

Ideal for desks, clean rooms, laboratories, computer stations, and pharmaceutical applications.



9000 hour lamp life.



Ideal for quick UVC disinfection.



PL-L 36W TUV, have no more than 4.5 mg mercury content and produce no ozone.

Models

There are two available models using 1 or 2 Philips PL-L UV 36W lamps.

UVS Series

SURFACE DISINFECTION UVC FIXTURES

UVS Product Specifications

Standard Specifications

Wavelength	254 Nanometers*
Expected Lamp/Bulb Rated Life ¹	18 months
Input Voltage	Self Regulated Electronic UV Ballast 120V
Electrical Requirement	UVS-136 0.30A @ 120V to 0.15A @ 240V, 50-60Hz UVS-236 0.60A @ 120V to 0.30A @ 240V, 50-60Hz
Weight	UVS-136 9 lbs UVS-236 10 lbs
Housing Finish	Aluminum

Certifications:



ASHRAE	meets ASHRAE TC 2.09
EPA ²	EST. NO. 91347-TN-001
ETL	CDR100230620ATL-001A

Warranty	Lamps/2 years; Parts/5 years
----------	------------------------------

¹With 80% utilization
²The manufacturer is registered with the US EPA. Clinical lab testing has been performed in independent labs.

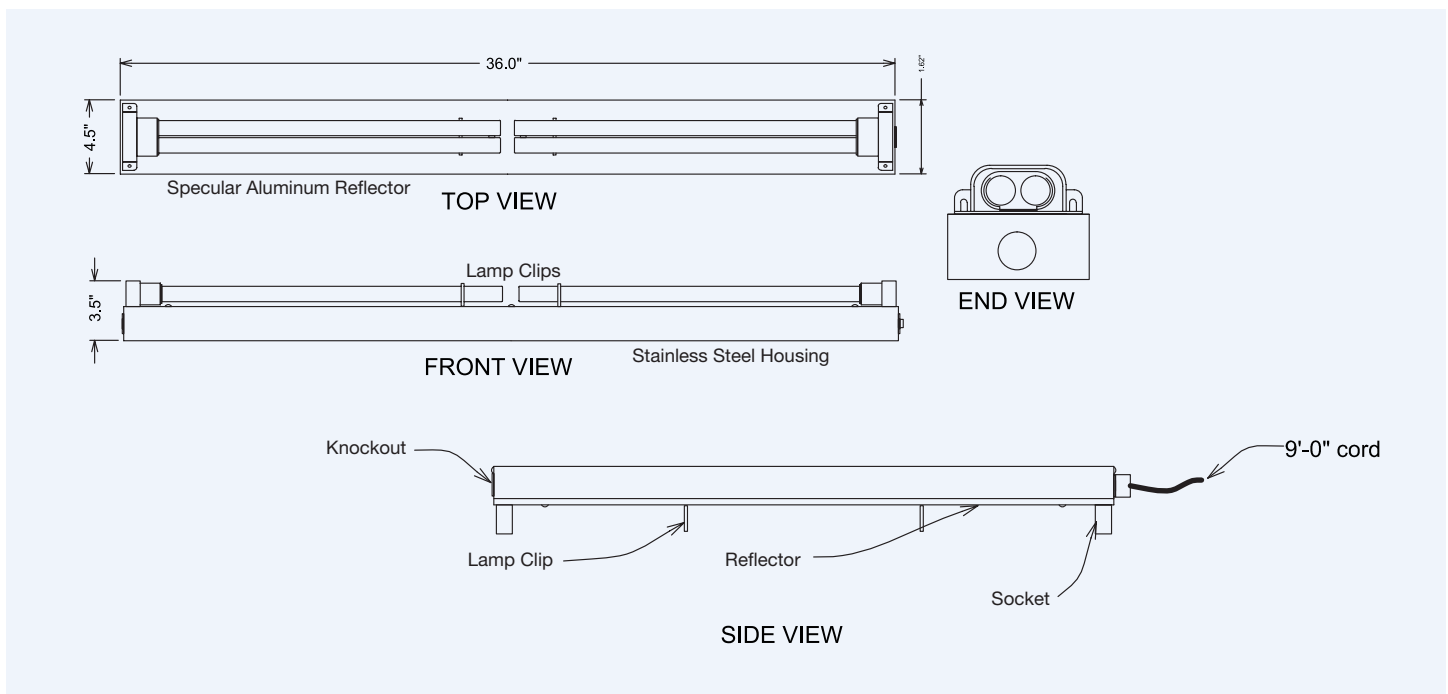

Due to continuing research, Lumalier reserves the right to change specifications without notice.

Ordering Guide

Model#	Description
UVS-136	One (1) 36Watt downward facing lamp for personal workspace surface disinfection
UVS-236	Two (2) 36Watt downward facing lamps for personal workspace surface disinfection